

9500MP

9500MP Encoder Detail

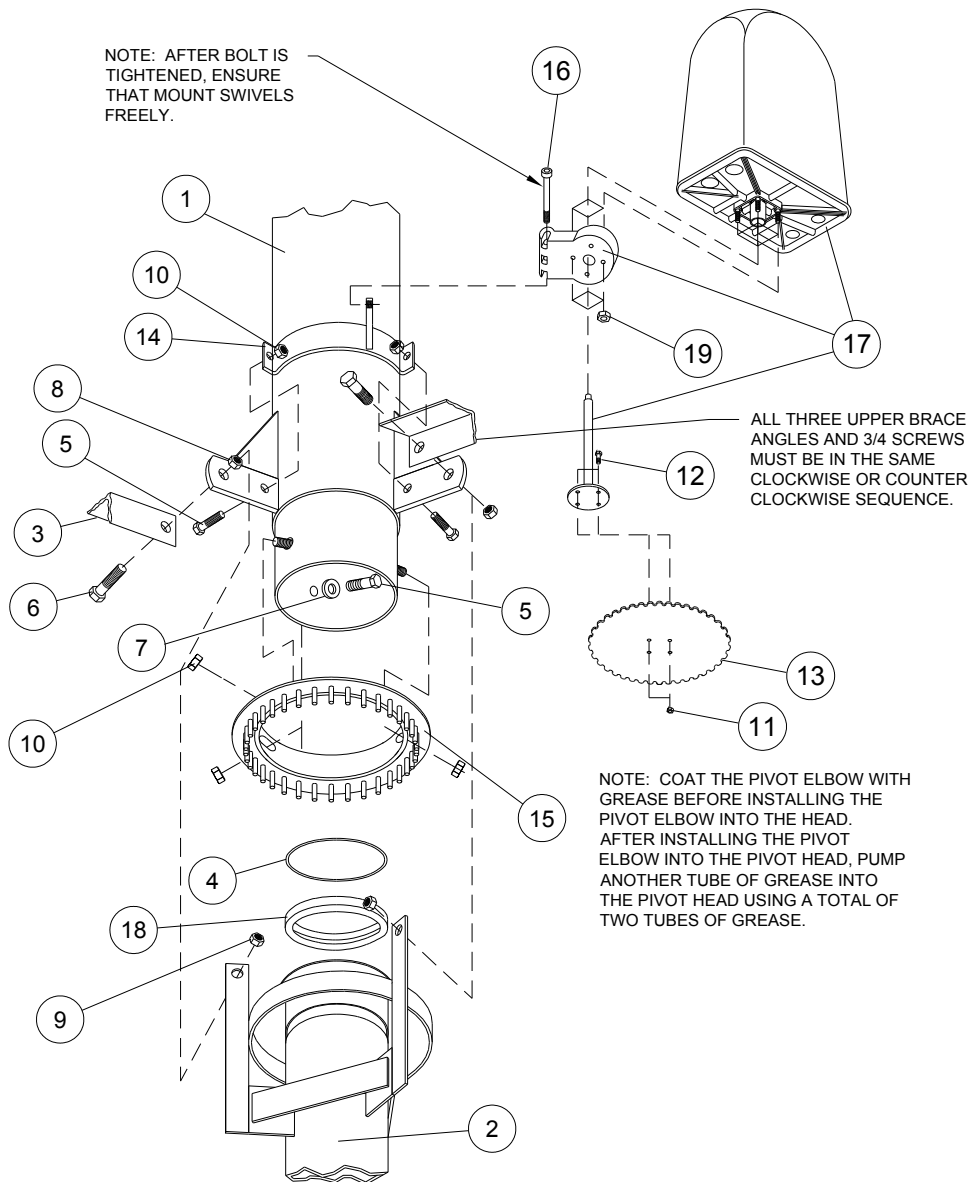

Ref.	Original Part No.	Substitute Part No.	Description
1	03-4206-3		Head Weldment, Mobile Pivot
2	03-7162-5		Riser Weldment
3	04-7265-4		Brace, Upper, Riser
4	06-0794-5		Gasket, Deflector, 8"
5	06-0804-2		Screw, 1/2-13 x 1-1/4" Hex, Gr. 5
6	06-0809-1		Screw, 3/4-10 x 2", Hex, Gr. 5
7	06-0820-8		Washer, 1/2", Rubber Seal
8	06-2368-6		Nut, 3/4-10, Hex, Jam
9	06-2417-1		Nut, 3/4-10, Lock
10	06-2418-9		Nut, 1/2-13, Lock

Ref.	Original Part No.	Substitute Part No.	Description
11	06-4267-8		Nut, 1/4-20, Lock, Nylon Insert
12	10-2985-9		Screw, 1/4-20 x 3/4", Hex, Gr. 5
13	11-0362-1		Gear, 10" Encoder Drive, Plated
14	11-0947-9		Clamp Weldment
15	11-0951-1		Pin Gear Weldment
16	11-6419-3		Screw, 5/8" x 3-1/2", Socket Hd.
17	13-9490-0		Panel, Assy, Encoder. Mag. Drive
18	66-1070-3		Gasket, Round Back
19	06-4364-3		Nut, 5/16-18, Lock